



COMPACT POST HOLE DIGGER



MODEL NO. PD24450 (24045000)

OWNER'S MANUAL

ASSEMBLY & OPERATING INSTRUCTIONS



THIS SAFETY ALERT SYMBOL IDENTIFIES IMPORTANT SAFETY MESSAGES IN THIS MANUAL. FAILURE TO FOLLOW THIS IMPORTANT SAFETY INFORMATION MAY RESULT IN SERIOUS INJURY OR DEATH.

Table of Contents

	Page(s)
Important Safety Information	1-4
Intended Use	1
Personal Protective Equipment	1
Safety Decals	1-3
General Safety and Preparation	3
Operating Safety	3-4
Repair and Maintenance Safety	4
Assembly Instructions	5
General Maintenance	6
Operating Instructions	6
Parts List	7
Parts Breakdown Illustration	8
Cutting Edges and Point Parts List	9
Notes	10
Specifications	11
Ordering Information	11



IMPORTANT SAFETY INFORMATION



WARNING: Read and thoroughly understand all instructions and safety information before assembling or operating this post hole digger. Failure to do so may cause serious injury or death. Do not allow anyone to operate this post hole digger who has not read this manual. As with all power equipment a post hole digger can be dangerous if assembled or used improperly. Do not operate this post hole digger if you have doubts or questions concerning safe operation. Call our customer service department at 1-800-525-8322 to address these concerns.

Si no entiende ingles, se prefiere que busque alguien que interprete las instrucciones para usted.

INTENDED USE

This product is designed to dig holes in the soil when attached to the 3-point linkage system and power-take-off of a tractor. It is **not** intended for any other use. Using the product for anything other than digging holes could result in serious injury or death.

PERSONAL PROTECTIVE EQUIPMENT



ALWAYS use appropriate personal protective equipment such as protective eyewear and safety shoes when operating this post hole digger.

NEVER wear loose clothing or jewelry that could become entangled in the auger or driveline.

SAFETY DECALS

ALWAYS replace missing or defaced decals. Reorder from SpeeCo, Inc., 15000 W. 44th Ave., Golden, CO 80403 or call 1-800-525-8322.

 DANGER		
	Rotating Parts Hazard Keep Away To Prevent Serious Injury or Death from Rotating Parts:	
	<p><i>Si no entiende ingles, se prefiere que busque a alguien que interprete las instrucciones para usted.</i></p> <ul style="list-style-type: none"> ● Read and understand owner's manual before operating. ● Do not operate without all shields and guards in place. ● Do not use body weight to force the auger into the ground or to locate auger point when auger is turning. ● Keep away from auger, cutting head and driveline when engine is running. <p style="text-align: right; font-size: small;">PHDC 1</p>	

PART NUMBER: DL5202010
LOCATION: TOP OF BOOM ON GEAR BOX END



IMPORTANT SAFETY INFORMATION



DANGER

TO PREVENT SERIOUS INJURY OR DEATH:

Si no entiende ingles, se prefiere que busque a alguien que interprete las instrucciones para usted.

- Read and understand owner's manual before operating.
- Operate only from the tractor seat.
- Stay away from rotating parts. Keep others away.
- Do not dig around underground utility lines without checking with authorities.

PHDC 2

PART NUMBER: DL52020200

LOCATION: UPPER RIGHT SIDE OF BOOM



DANGER



**Rotating Driveline
CONTACT CAN CAUSE DEATH
KEEP AWAY!**

DO NOT OPERATE WITHOUT-

- ALL DRIVELINE GUARDS, TRACTOR AND EQUIPMENT SHIELDS IN PLACE
- DRIVELINES SECURELY ATTACHED AT BOTH ENDS
- DRIVELINE GUARDS THAT TURN FREELY ON DRIVELINE

PART NUMBER: DL51019200

LOCATION: PTO DRIVE SHAFT SHIELD



DANGER

TO PREVENT SERIOUS INJURY OR DEATH:

- Contact dealer, make sure your machine has all current safety guards and shields in place.
- Do not operate without all guards and shields in place.
- Do not operate when auger is higher than 12 inches above ground level. Doing so may cause driveline to bind, resulting in equipment damage or operator injury.
- Stop auger rotation before maneuvering, relocating or transporting.

PHDC 3

PART NUMBER: DL52020300

LOCATION: UPPER LEFT SIDE OF BOOM AND PTO DRIVE SHAFT SHIELD

ATTENTION

540 RPM MAXIMUM

PTO OPERATING SPEED ⑨

PART NUMBER: DL51011900

LOCATION: PTO DRIVE SHAFT SHIELD



DANGER

DO NOT ATTACH THIS IMPLEMENT OR ATTEMPT TO OPERATE UNTIL YOU HAVE READ AND UNDERSTOOD ALL INSTRUCTIONS IN THE OWNER'S MANUAL. IF AN OWNER'S MANUAL IS NOT AVAILABLE CONTACT SPECIAL PRODUCTS CO., 15000 W. 44th AVE., GOLDEN, CO 80403-1824 PHONE 303-279-5544

PHDC 4

PART NUMBER: DL52020400

LOCATION: BOTH SIDES OF GEAR BOX SHIELD



IMPORTANT SAFETY INFORMATION

 DANGER		
GUARD MISSING When this is visible DO NOT OPERATE		KEEP CLEAR! Keep Others Away! ENTANGLEMENT HAZARD <i>can cause Serious Injury or Death</i>
<i>Si no entiende ingles, se prefiere que busque a alguien que interprete las instrucciones para usted.</i>		
<ul style="list-style-type: none">● Never manually position the auger or manually force the auger into ground.● This machine is designed to be operated ONLY from the tractor seat.● Keep everyone clear of all moving parts of the digger while in operation.		
<small>PHDC 5</small>		

PART NUMBER: DL52020500

LOCATION: TOP END OF AUGER TUBE

NOTE: IF THE OUTPUT SHAFT GUARD MENTIONED IN THE ABOVE DECAL IS MISSING, YOU MAY ORDER A REPLACEMENT BY CALLING US AT 1-800-525-8322.

GENERAL SAFETY AND PREPARATION

ALWAYS make sure that anyone else who operates this post hole digger has read and understood the contents of the owner's manual and all safety decals on the product.

ALWAYS be certain that all members of the work party are familiar with the operation of the digger and the hazards associated with it.

ALWAYS check with authorities for underground utilities before digging a hole. Serious injury or death could result from contact with gas or electric lines.

ALWAYS check the tractor owner's manual for instructions on operation, attachment of 3-point equipment and safety.

ALWAYS make sure that all safety shields are in place and tightened down. Do not operate this post hole digger if any shields are missing. Contact SpeeCo, Inc. at 1-800-525-8322 for replacement part(s).

ALWAYS make sure that the auger point and cutting edges are intact and in good working order before using this digger.

OPERATING SAFETY

ALWAYS operate this post hole digger from the tractor seat. Only one person should operate the digger.

NEVER attach the post hole digger with the tractor engine running.

NEVER operate the post hole digger with anyone near or in contact with any part of the implement, PTO driveline or auger. Serious injury or death could result from entanglement with moving parts.



IMPORTANT SAFETY INFORMATION

ALWAYS make sure that the tractor brake is set before digging a hole.

ALWAYS keep hands, feet and clothing away from power-driven parts during operation.

NEVER manually position the auger or manually force the auger into the ground.

ALWAYS make sure that the tractor engine is shut off and the PTO drive is disengaged before leaving the tractor seat.

NEVER move the tractor with the power-take-off in the ON position.

NEVER exceed 540 RPM PTO operating speed.

NEVER operate the post hole digger when the auger point is more than 6 in. above ground level. Operating the digger in elevated positions may cause the PTO driveline "U" joints to bind resulting in equipment damage and operator injury.

ALWAYS turn off the digger immediately if an immovable object is encountered to prevent damage to the gear box or driveshaft and possible injury. A shear bolt is provided but may become welded to the input shaft if the driveshaft is left running after being sheared.

REPAIR AND MAINTENANCE SAFETY

ALWAYS perform maintenance operations such as lubrication, adjustments or repairs on the post hole digger with the tractor engine off, the PTO drive disengaged and the auger point resting on the ground.

ALWAYS use the correct shear bolt (Grade 5). **NEVER** use or replace the shear bolt with one that is longer than the one specified in the manual (5/16" x 2-1/2").

ASSEMBLY INSTRUCTIONS

- IMPORTANT:** The gear box is shipped without lubricant. Fill the top hole with EP 90 lubricant or the equivalent. The gear box holds 25 oz. (0.7 liter). Fill to the bottom of the plug hole on the side. Do not fill to overflow point as this may damage the seals.
- STEP 1:** Be certain that the gear box has adequate lubrication. Check the oil level after every fifty hours of use.
- STEP 2:** Attach the boom (1) to the top link mounting bracket on the tractor using a top link pin and a lynch pin (not provided) through the hole at the bottom of the boom.
- STEP 3:** Connect the "A" frame (5) to the tractor's 3-point lift arms using the 7/8 in. pull pins with nut and lockwasher (5A) as shown in the drawing. Attach the "A" frame (5) to the boom (1) after selecting the desired hole (for angle adjustment) using the "A" frame pin (6) and lynch pin (4).
- STEP 4:** Attach the gear box (10) to the boom (1) using the boom pin provided with the gear box. When in place secure with cotter pins provided. NOTE: Input shaft shield (9) and output shaft shield (23) are already attached to the gear box.
- STEP 5:** Attach the auger (20, 21 or 22) to the output shaft on the bottom of the gear box (10) using the 1/2 in. hex cap screws (17), 1/2 in. lockwashers (18) and 1/2 in. hex nuts (19). Tighten the nuts.
- STEP 6:** Attach the driveline (13) to the gear box input shaft using the 5/16 in. grade 5 hex cap screw (14), the 5/16 in. lockwasher (15) and the 5/16 in. NC hex nut (16). Tighten the hex nut. Insert the 1/4 in. x 3/8 in. set screw from the hardware kit in the hole on the yoke that aligns with the 3/16 in. groove on the gear box input shaft. Tighten.
- ATTENTION:** THE 5/16 IN. HEX CAP SCREW PROVIDES SHEAR PROTECTION. USE A GRADE 5 2-1/2" BOLT ONLY TO AVOID DAMAGE TO THE GEAR BOX OR AUGER.
- IMPORTANT:** The universal joint should be greased with a good grade chassis lube every week. At the beginning of each season grease the sliding driveshaft members with a moly grease. All diggers are equipped with quick-detach universal joints on the power-take-off end for a 1-3/8 in. splined shaft.
- STEP 7:** Attach the tractor end of the driveline (13) to the tractor PTO shaft. Push in the spring-loaded pin in the splined yoke (13E) and slip it on the splined PTO shaft of the tractor. Release the pin and push until it locks securely in place. It will be necessary to obtain a 1-1/8 in. to 1-3/8 in. sleeve spline adapter if your tractor PTO shaft has a 1-1/8 in. spline.
- STEP 8:** Attach and secure both chains on the driveline (13) to the boom (1). See illustration A.
- STEP 9:** Attach the handle (8) to the gear box (10) and secure with the 5/16 in. set screw in the gear box. Tighten.
- STEP 10:** Check all nuts and bolts for tightness. Stabilizers should be kept tight to avoid side sway of the digger.
- NOTE:** See illustration A for reference in assembling the digger and mounting it to the tractor. Note that the boom angle can be adjusted on your tractor for proper digging and ground clearance by moving the "A" frame to a different mounting hole as shown in illustration B.
- NOTE:** When the 7/8 in. diameter pull pins in the "A" frame are too small for the holes in the lift arms, bushings should be used to obtain a proper fit



ILLUSTRATION A

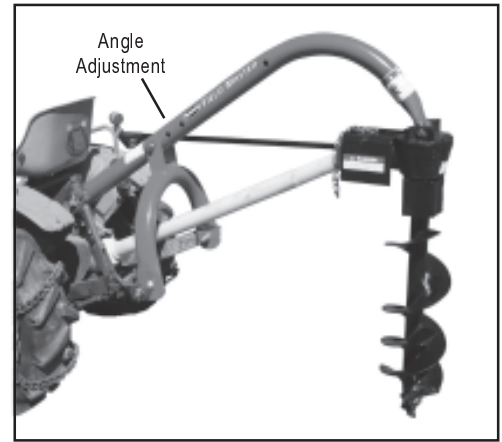

ILLUSTRATION B

OPERATING INSTRUCTIONS



WARNING: Read and thoroughly understand all instructions and safety information before operating this post hole digger. Failure to do so may cause serious injury or death. Do not allow anyone to operate this post hole digger who has not read this manual.

STEP 1: After mounting the digger to the tractor, lower the auger point slowly to the ground at the desired digging angle before engaging power.

STEP 2: Engage the power-take-off and start digging at a slow speed, lowering the auger slowly as it begins to dig.

STEP 3: Increase speed as the auger goes deeper. The type of soil will determine the proper auger speed. If the soil is extremely hard, it will generally improve operation to vary the speed of the auger at times. If an object is encountered which is too large for the auger to move, the digger will begin to vibrate. Withdraw the auger and remove the obstacle.

STEP 4: When the auger has reached the desired depth, spin it momentarily at a high speed to clear the hole of dirt. Reduce speed before withdrawing the auger from the hole.

STEP 5: Disengage the power-take-off after withdrawing from the hole and move the tractor to the next hole location.

GENERAL MAINTENANCE

REFER TO ILLUSTRATION C



WARNING: Always perform maintenance operations with the tractor engine off, the PTO drive disengaged and the auger point resting on the ground.

1. To remove the auger from the gear box output shaft, take out the two 1/2 in. x 3 in. hex cap screws (17).
2. To remove the driveshaft from the gear box input shaft, take out the shear pin bolt (14) and 1/4 in. set screw (13j).
3. To remove the auger control handle (8), loosen the 5/16 in. set screw in the side of the gear box (10).
4. Check the oil level after every fifty hours of use. Use EP 90 lubricant and fill to oil level plug. All replacement lubricant should be of this type.
5. The universal joints should be greased with a good grade chassis lube every week. At the beginning of each season, grease the sliding driveshaft members with a moly grease.

COMPACT POST HOLE DIGGER PARTS BREAKDOWN

REFERENCE NUMBER	SKU NUMBER	PART NUMBER	DESCRIPTION	NUMBER REQUIRED
	24045000	PD24540	Compact Post Hole Digger less Auger	1
1	24084600	PD24846	Boom	1
4	07090100	*P791	7/16 in. Lynch Pin	1
5	24084700	PD24847	"A" Frame	1
5A	07020800	*P728	7/8 in. Pull Pin with Nut and Lockwasher	2
6	07071500	*P7715	"A" Frame Pin	1
7	24082200	*PD24822	Handle Grip	1
8	24084100	PD24841	Control Rod	1
9	24073800	PD24738	Gear Box Shield	1
10	24075500	PD24755	Gear Box with Shields	1
13	240620CH	PD2462CH	Driveline with Plastic Shield	1
13A	240617CH	PD24617CH	Gear Box End "U" Joint Yoke	1
13B	240615CH	PD24615CH	"U" Joint Cross Assembly	2
13C	240611CH	PD24611CH	Inner Tube-Yoke and "U" Joint (Gear Box End)	1
13D	240612CH	PD24612CH	Outer Tube Yoke and "U" Joint (Tractor PTO End)	1
13E	240616CH	PD24616CH	"U" Joint Yoke (Tractor PTO End)	1
	240619CH	PD24619CH	Push Pin Kit for Tractor Yoke	1
13F	240614CH	PD24614CH	Inner Shield Tube Only	1
13G	240613CH	PD24613CH	Outer Shield Tube Only	1
13H	240659CH	PD24659CH	Guard Ring for Inner Tube	1
13I		HW171322	Roll Pin	2
13J		* O/L	1/4 in. x 3/8 in. Set Screw	1
13M		HW17156	Grease Fitting	2
13N	240656CH	PD24656CH	Guard Ring for Outer Tube	1
14		* O/L	5/16 in. x 2-1/2 in. Hex Cap Screw (Grade 5 Shear Bolt)	1
15		* O/L	5/16 in. Lockwasher	1
16		* O/L	5/16 in. NC Hex Nut	1
17		* O/L	1/2 in. NC x 3-1/2 in. Hex Cap Screw	2
18		* O/L	1/2 in. Lockwasher	2
19		* O/L	1/2 in. NC Hex Nut	2
20	24054600	PD24546	6 in. Auger with Screw Point and Cutting Edges	as required
21	24054700	PD24547	9 in. Auger with Screw Point and Cutting Edges	as required
22	24054400	PD24544	12 in. Auger with Screw Point and Cutting Edges	as required
23	24073900	PD24739	Output Shaft Shield	1
	24045100	*PD24451	Hardware Kit	1

O/L- Obtain Locally. Common fasteners available through hardware and farm stores.

ILLUSTRATION C

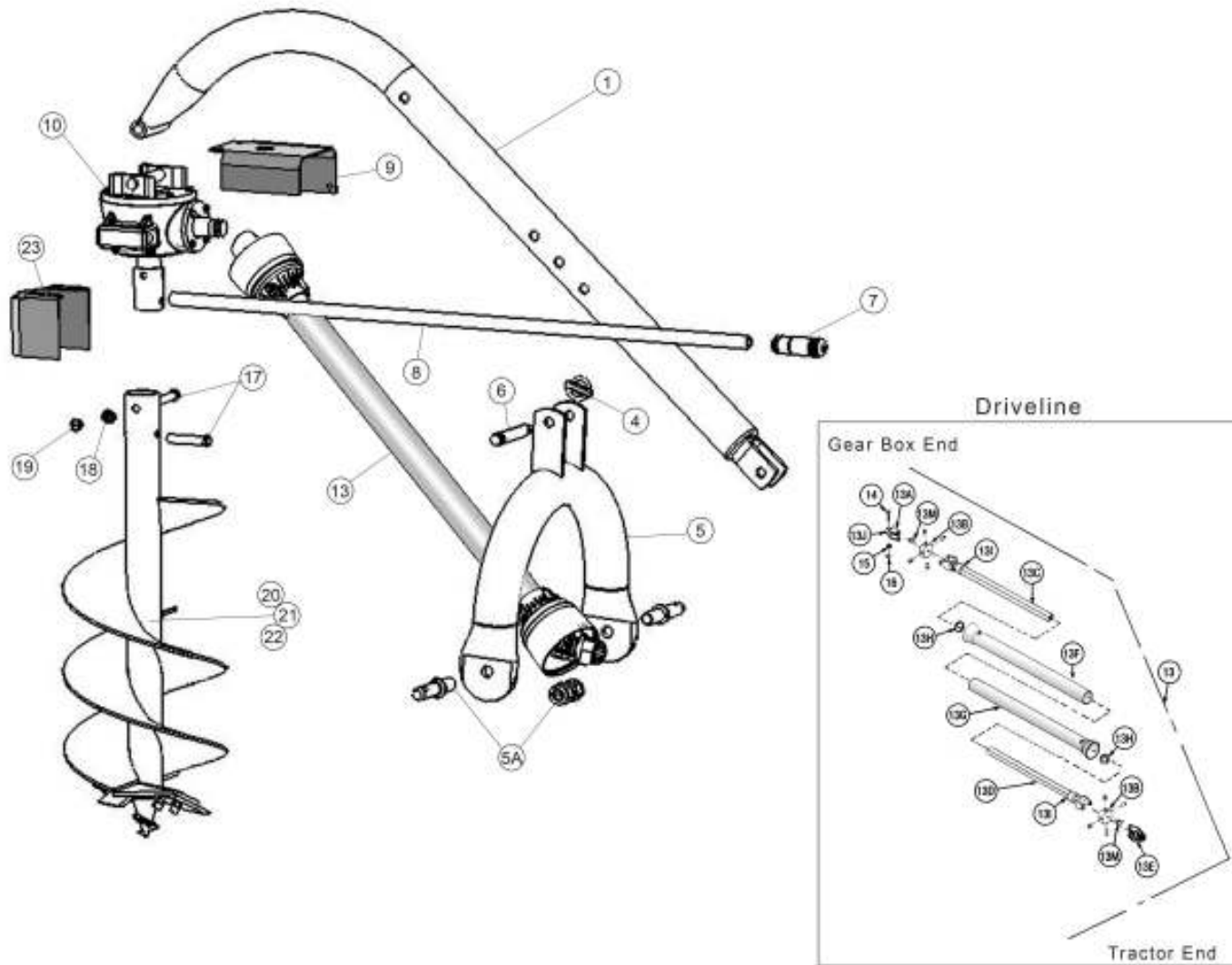

See Illustration D for Cutting Edges



NOTE: Safety shields are shaded on this diagram. NEVER operate the digger with any shield missing.

**COMPACT
POST HOLE DIGGER**

CUTTING EDGES AND POINT PARTS BREAKDOWN

REFERENCE NUMBER	PART NUMBER	DESCRIPTION	NUMBER REQUIRED	
1	24056700	PD24567	6 in. Cutting Edge	2
2A	24057700	PD24577	9 in. Outer Cutting Edge	1
2B	24057800	PD24578	9 in. Inner Cutting Edge	1
3	24058700	PD24587	12 in. Outer Cutting Edge	1
4	24058800	PD24588	12 in. Inner Cutting Edge	1
5	24059200	PD24592	Screw Point with 1-1/4 in. NC Threads	1
6	O/L	3/8 in. NC x 1-1/4 Carriage Bolt	4	
7	O/L	3/8 in. Lockwasher	4	
8	O/L	3/8 in. NC Hex Nut	4	

O/L- Obtain locally. Common fasteners available through hardware and farm stores

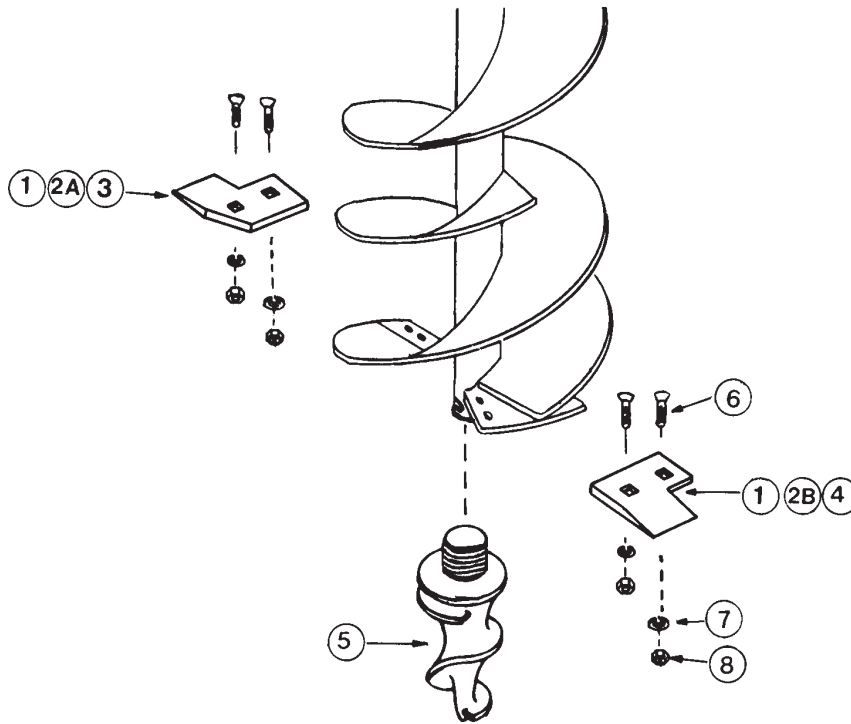

ILLUSTRATION D

NOTE: It is important to replace the self-sharpening point on the auger when it shows signs of excessive wear. Generally, the digging life of the point will be greater than that of the inner cutting edge. The digging life of the inner cutting edge will be greater than that of the outer cutting edge since it covers fewer inches of digging circumference.

== **NOTES** ==

Model No. _____

Date of Purchase _____

Place of Purchase _____

SPECIFICATIONS

Tractor Category	Subcompact , Category 0 and 1
Gear Box	3:1 Ratio, 2 in. output shaft to accept common augers
Driveline	Equipped with quick-tach yoke to fit standard 6-spline PTO (completely shielded)
Augers	6 in., 9 in. and 12 in. sizes available (sold separately)
Boom	2-7/8 in. O.D. high strength tubing
A-frame	2-7/8 in. high strength tubing
Safety Shields	On driveline, gear box "U" joint and gear box output shaft
Shear Bolt	On input shaft to protect driveline, auger and gears. Replaceable.

ORDERING INFORMATION

SKU NUMBER	PART NUMBER	DESCRIPTION
24045000	PD24450	Compact post hole digger less auger
24045600	PD24546	6 in. compact auger with screw point and replaceable cutting edges
24054700	PD245547	9 in. compact auger with screw point and replaceable cutting edges
24054400	PD24544	12 in. compact auger with screw point and replaceable cutting edges
24059200	PD24592	Screw point
240567ZBU	PD24567ZBU	6 in. cutting edge set
240579ZBU	PD24579ZBU	9 in. cutting edge set
240589ZBU	PD24589ZBU	12 in. cutting edge set
24086500	PD24865	Optional weight kit for increased auger penetration. Weights sold separately.



A brand of Special Products Co.
15000 W. 44th Ave. Golden Colorado 80403
303-279-5544 Toll Free USA 800-525-8322 Fax 303-278-3432
Email: speeco@speeco.com Web: www.speeco.com